

## RUSKII

### INSTALLATION MANUAL

E26 / E27 (120V/220V)  
GM  
Incandescent 100W max  
PLE-T Eco 42W max

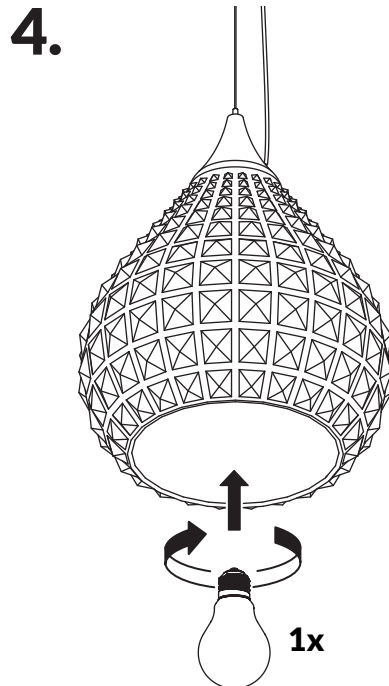
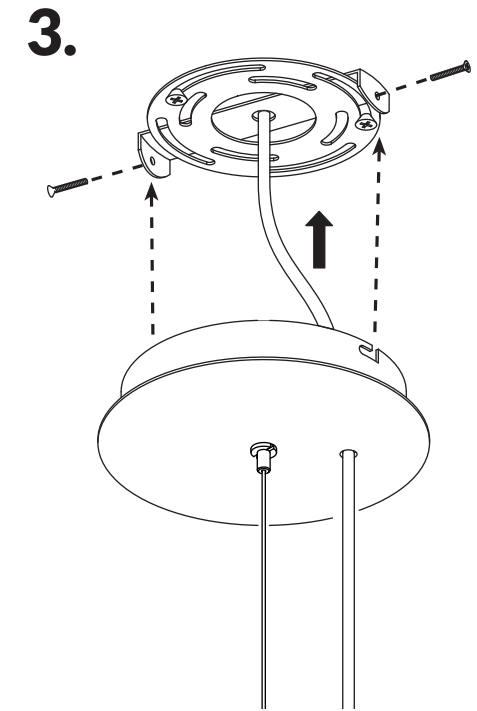
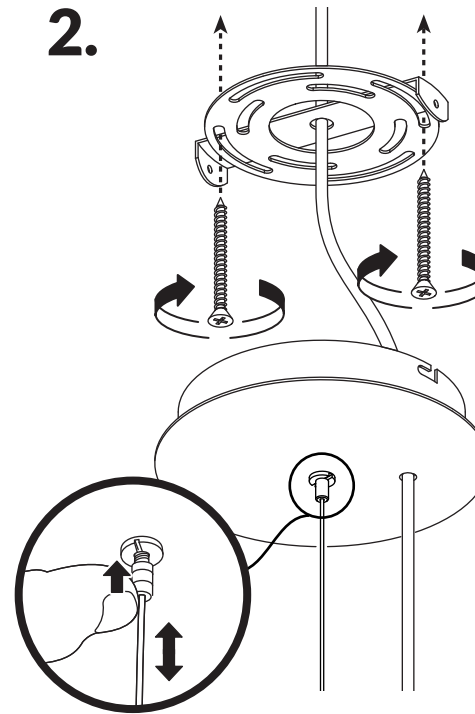
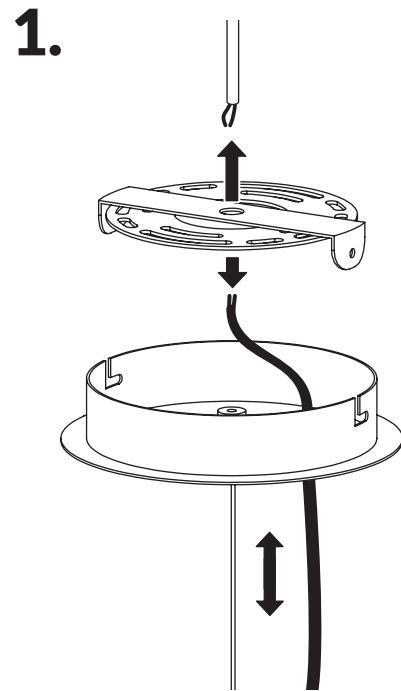

#### IMPORTANT

Always shut off power to the circuit before starting installation work.



All products are manufactured to meet or exceed North American standards C22-250, UL 1598, C22.2-12, C22.2.9, UL 153.

All preparation for installation of fixture is to be provided by the end user.

The description and measurements on this drawing are for information purposes only.

VISO inc // © 2014 // All rights reserved